

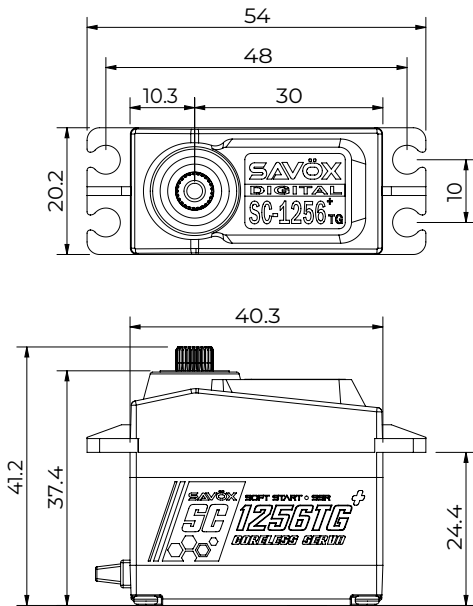

Line	BLACK EDITION
Application	CAR
Servo Size	Standard
Operating Voltage	4.8V-6.0V
Speed	0.15 s/60°
Torque	20 kg/cm   277.7 oz/in
Amplifier Type	Digital Controller
Motor Type	Coreless
Case Type	Hybrid (Aluminium/Composite)
Protection	Dust Resistant
Dimensions (L x W x H)	40.3 x 20.2 x 37.4 mm
Weight	64 g
Gear Type	Titanium

### DIMENSIONS



### PERFORMANCE RADAR

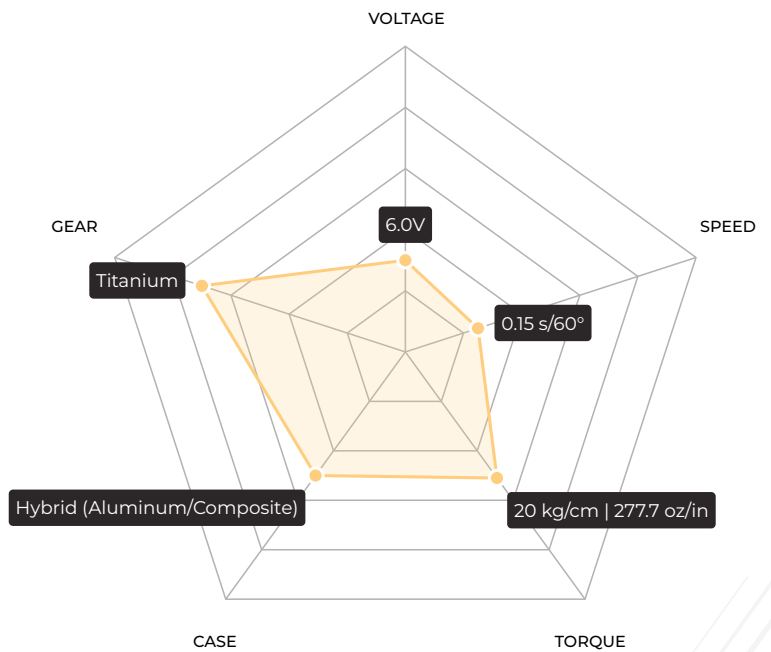

### DETAILED SPECIFICATION

Compatibility	Sanwa SSR	Potentiometer	VR
Speed @4.8V	0.18 s/60°	Cable	22 AWG 200 ±5 mm
Torque @4.8V	16 kg/cm   222.2 oz/in	Connector	JR Connector
Speed @6.0V	0.15 s/60°	Stall Current @4.8V	4000 mA
Torque @6.0V	20 kg/cm   277.7 oz/in	Operating Current @4.8V	100 mA
PCB Board	12-bit	Stall Current @6.0V	5000 mA
Rotating Direction	Counterclockwise (when 1500+2000 µsec)	Operating Current @6.0V	120 mA
Max Travel	~130° (when 900+2100 µsec)	Idle Current	5 mA
Operating Travel	100° (when 1000+2000 µsec)	Dead Band Width	3-5 µsec
Neutral Position	1500 µsec	Frequency Range	50-360 Hz
Horn Gear Spline	25T(Φ6)	Control System	Pulse width modification
Bearing	2x Ball Bearings	Operating Temperature	-10°C to 50°C